



A140 AIR

Automations for sliding doors

FAAC
Simply automatic.

energy  saving

A140 AIR

The right solution for all your needs

Solutions with cover h 100 mm

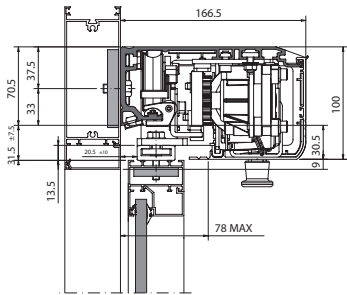

With commercial profiles

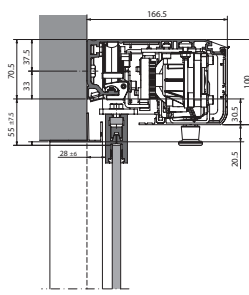

With FAAC glass clamp system

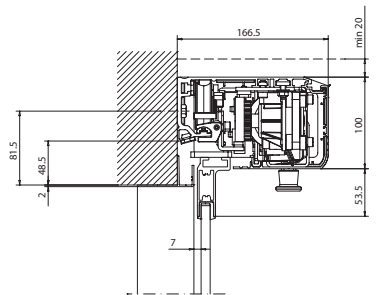

With reduced section profiles FAAC TK20

Solutions with cover h 140 mm

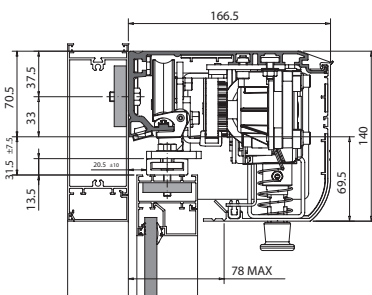

With commercial profiles

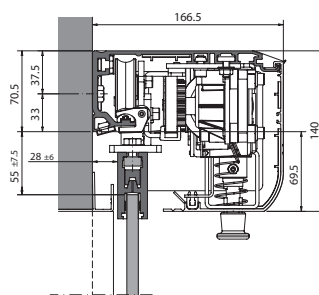

With FAAC glass clamp system

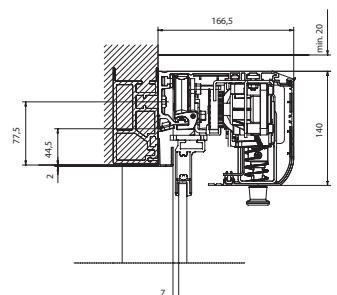

With reduced section profiles FAAC TK20

Solutions with special versions h 100 mm and h 140 mm

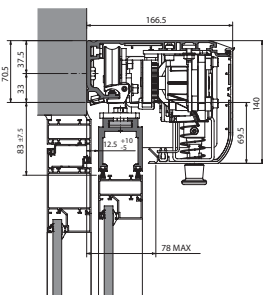

With profiles for APN anti-panic break-out systems

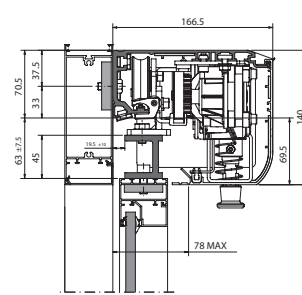

With spacers

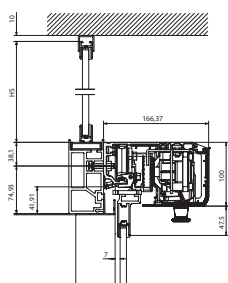

With self supporting profile, transform-light and reduced section profiles FAAC TK20

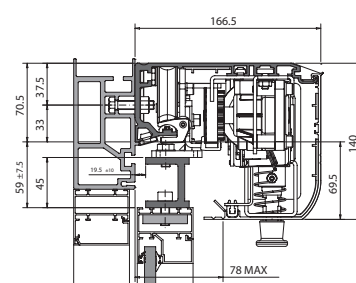

With self supporting profile and spacers



The future is here

A140 AIR

The first automated system for sliding doors designed to meet the needs of the market as well as protect our environment.

A140 Air is the first automated system that respects our planet.

Thanks to its innovative “Energy Saving” device it identifies the direction of transit and perfectly optimizes opening/closing times to avoid unnecessary air dispersion, even in case of sideways transit. This device allows energy saving and optimizes temperature sudden changes in the room and near to the doors.

All in absolute safety.

A140 Air features an ETHERNET interface for setting the operating parameters of the automated system and viewing the fault diagnostics with a PC connected to the network.

The A140 Air automated system is customizable and modular to meet the architectural and technical needs of the customer. Thanks to the two different covers, the exclusive leaf fitting systems and the different leaf profiles that can be used, it is possible to create the best technical and architectural solution.

Designed to operate at best in any condition and in any environment, it is the optimum solution for those technicians who wish to save assembly time, by rationalizing the inventories for the final customer who will have full access to a product that is personalized, ecological, reliable, safe, technologically advanced and above all that will pay for itself over time.



Technical specifications

A140 AIR

Electric power supply	115/230 Vac - 50 /60 Hz
Power consumption	100 W
Frequency of use	100%
Drive unit	24 Vdc with encoder
Head profile length	VP x 2 + 100 mm
Opening speed (adjustable)	5 to 80 cm/sec. / 10 to 160 cm/sec.
Closing speed (adjustable)	5 to 70 cm/sec. / 10 to 140 cm/sec.
Partial opening adjustment	10% to 90% of total opening
Pause Time adjustment	0 to 30 sec.
Night pause Time adjustment	0 to 240 sec.
Anti-crushing device	standard
Photocells fail safe	standard (can be excluded)
Protection class	IP 23 (for indoor use only)
Environmental temperature	-20°C to + 55°C



A140 AIR

3 Sliding carriages



Carriages with plastic wheels on special aluminium alloy sliding track on vibration-damping seal. Brush for cleaning the sliding track.

1 Motor with electroloc

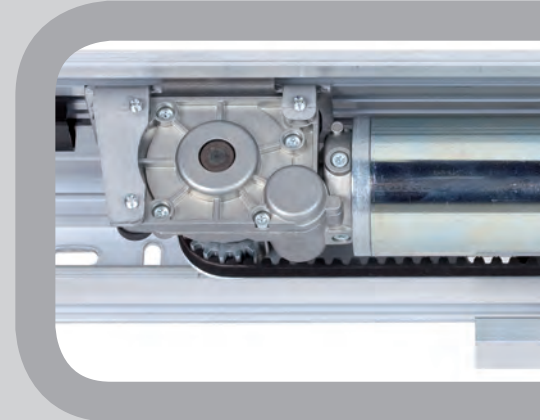

Automatic adjustments

Identification of open and close positions.
Measurement of leaf weight and friction.
Speed selection, optimal acceleration and deceleration.
Photocell test.
Anti-crushing safety device at 150 N.

Accessories

Button photocell.
Passive infrared sensor.
Microwave radar.
Push-buttons, key-operated push-buttons with emergency release device.
Clamping profiles for glass leaves.
Electromechanical motor lock with manual release.
Motor lock monitoring
Emergency batteries. Guarantee a 30-minute range of continuous use.

Anti-panic break-out system.



Compatible with the new series of FAAC TK20 and TK50 profiles
Wireless selector switch.

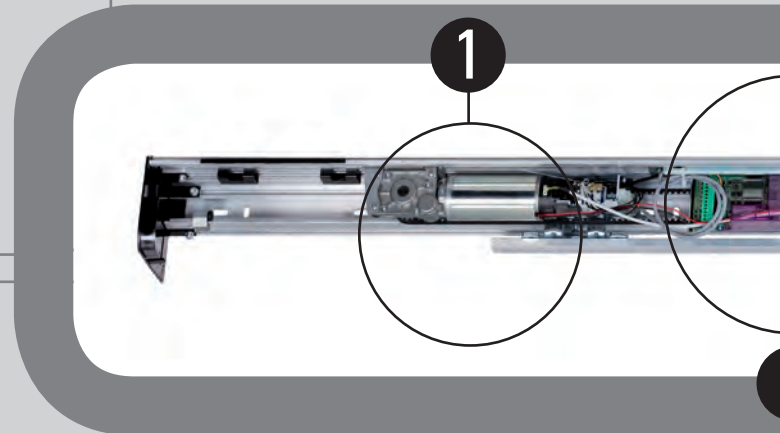

5 Slots for rapid mechanical assembly

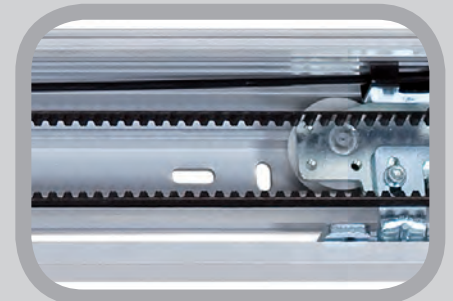

Thermal dispersion reduction device

energy saving

Designed for
ETHERNET
connection

k

2 Control unit with switching power supply

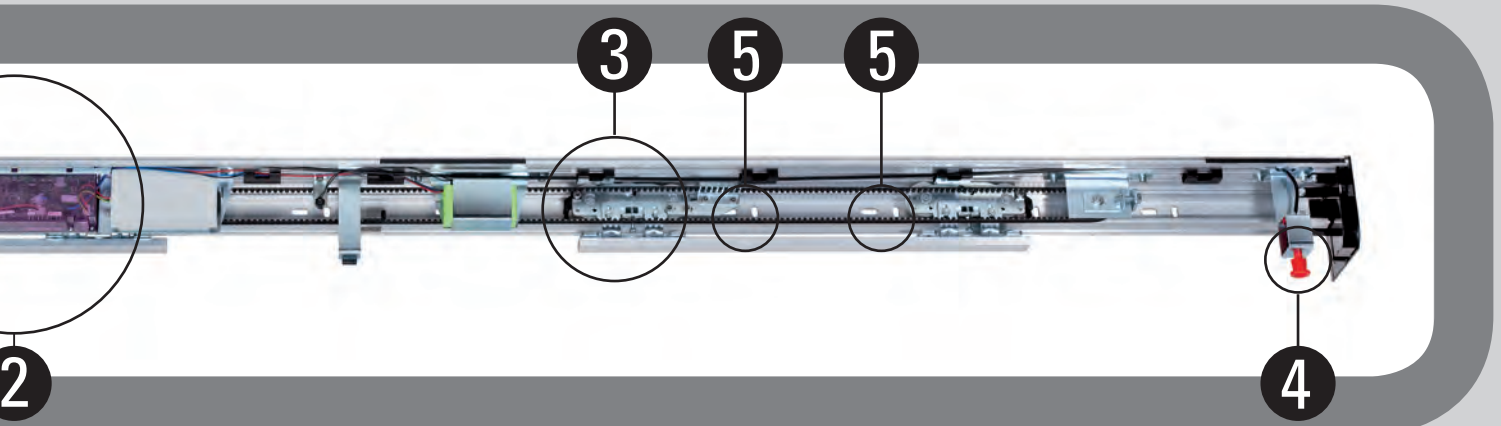
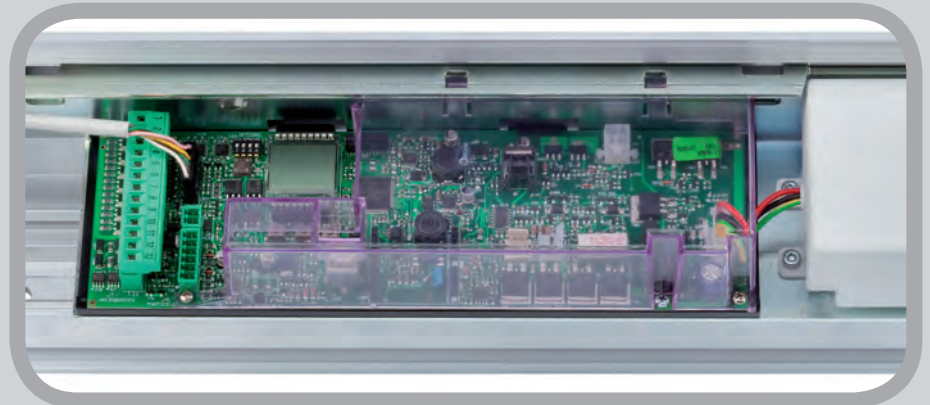
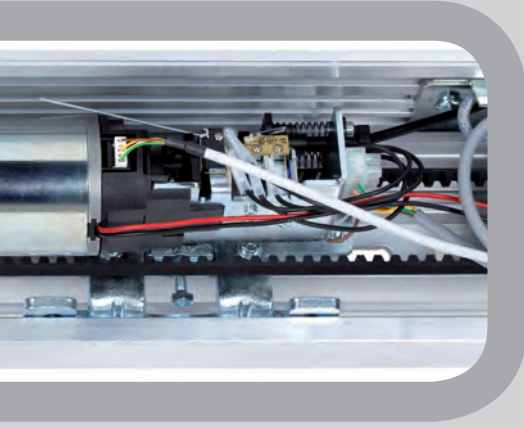

4 Knob for manual release

Wireless selector switch

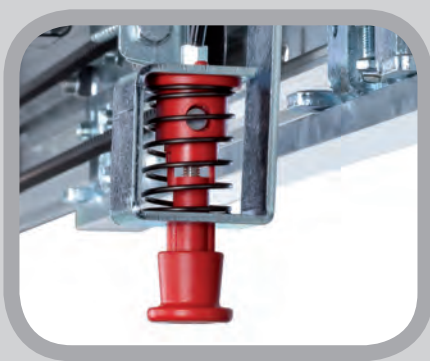

Thanks to calendar management it can be programmed by time bands



Use

Model	Leaf	Passage width (mm)	Leaf max weight (kg)	Self supporting head profile length in mm
A140 AIR 1	single	700-3000	200 Kg	NO
A140 AIR 2	double	800-3000	120 + 120 Kg	NO
A140 AIR 1 A	single	700-3000	200 Kg	Yes (max 2500 mm)
A140 AIR 2 A	double	800-3000	120 + 120 Kg	Yes (max 2500 mm)

A140 AIR

PROGRAMMING DISPLAY

Main functions

Access password insertion
Closing speed adjustment
Pause time adjustment
Diagnostic display

Opening speed adjustment
Anti-break-in function management
Anti-crush adjustment
Weekly calendar management

Interlock management with or w/o memory
Selection of battery operating logics
1 output configuration on control unit
2 emergency inputs configuration on control unit
Cycle counter visualization
Daily time bands (5) management



Programming display

SD KEEPER FUNCTIONS KEYBOARD

Main functions

Manual
Automatic
One-way
Reset

Open
Partial opening
Night
One-way partial

Trouble shooting through a combination of flashing leds
Operation inhibition by jumper or push buttons combination
Preset for programming Display connection



SD Keeper function keyboard

SDK LIGHT FUNCTION KEYBOARD

Main functions

Manual
Automatic
One-way
Reset

Open
Partial opening
Night
One-way partial

Trouble shooting through a combination of flashing leds
Operation inhibition by push buttons combination
Not designed for programming Display



SDK light function keyboard

SDKW WIRELESS FUNCTIONS KEYBOARD

Main functions

Manual
Automatic
One way

Open
Partial opening
Night

Can manage up to 2 automated systems groups



SDKW wireless functions selector switch

THERMOTOOL - Energy saving quantification

The “Energy Saving” device of A140 Air perfectly optimizes door opening/closing times, to avoid unnecessary dispersion of air. This is done to limit the consumption of energy of the air-conditioning and heating systems with huge benefits in terms of economic savings and reduction of polluting emissions (CO₂).

To prove the efficiency of the Energy Saving device, a dedicated software tool called THERMOTOOL has been designed, in cooperation with BEA and the University of Liège (Belgium). THERMOTOOL allows to quantify energy savings in terms of both economic savings and reduction of CO₂ polluting emissions, based on the dimensional characteristics and the geographical position of the automated entrance.

THERMOTOOL is an effective, user-friendly tool and can be consulted at the web site www.faac.it in the section dedicated to the A140 Air automated system.

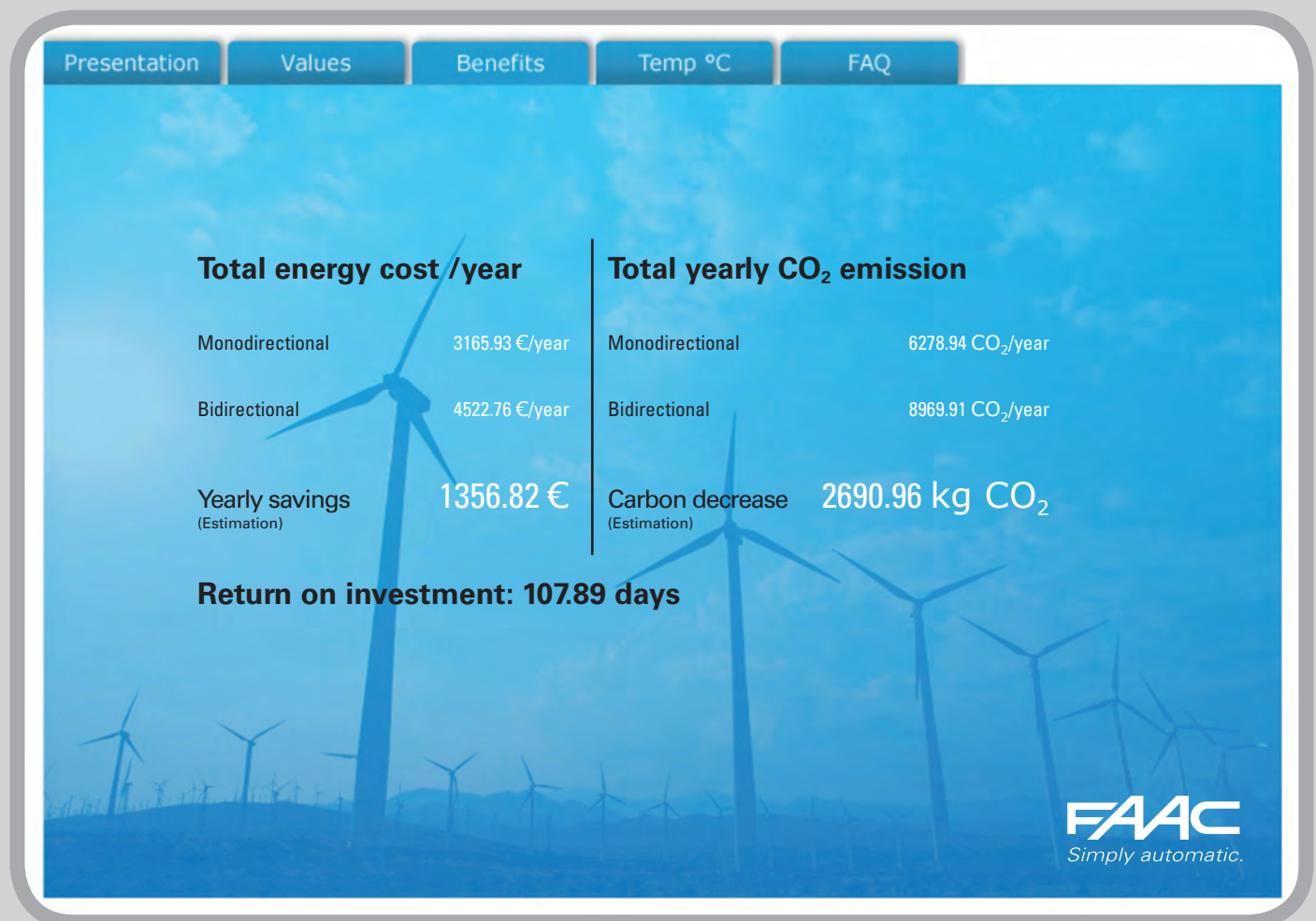

A140 AIR quality compliance

NEMKO certification for 2,000,000 cycles (opening and closing) in compliance with the DIN 18650-1 standard.

Compliant with the safety standards of the Low Voltage Directive (2006/95/EC), Electromagnetic Compatibility Directive (2004/108/EC) and the Machinery Directive (2006/42/EC), CE mark.

HEADQUARTERS

ITALY

FAAC SpA
Via Calari 10 - 40069 Zola Predosa (BO)
Tel. +39 051 61724 - Fax +39 051 758518
info@faac.it - www.faac.it

SUBSIDIARIES

AUSTRALIA

FAAC AUSTRALIA PTY LTD
Homebush – Sydney, Australia
tel. +61 2 87565644
fax +61 2 87565677
www.faac.com.au

AUSTRIA

FAAC GMBH
Salzburg, Austria
tel. +43 662 8533950
fax +43 662 85339525
www.faac.at

BENELUX

FAAC BENELUX NV/SA
Brugge, Belgium
tel. +32 50 320202
fax +32 50 320242
www.faacbenelux.com

CHINA

FAAC SHANGHAI
Shanghai, China
tel. +86 21 68182970
fax +86 21 68182968
www.faacgroup.cn

FRANCE

FAAC FRANCE
Corbas - Lyon, France
tel. +33 4 72218700
fax +33 4 72218701
www.faac.fr

FRANCE - AGENCE PARIS

Massy - Paris, France
tel. +33 1 69191620
fax +33 1 69191621
www.faac.fr

GERMANY

FAAC GMBH
Freilassing, Germany
tel. +49 8654 49810
fax +49 8654 498125
www.faac.de

INDIA

FAAC INDIA PVT. LTD
Noida – Delhi, India
tel. +91 120 3934100/4199
fax +91 120 4212132
www.faacindia.com

MIDDLE EAST

FAAC MIDDLE EAST BRANCH
Dubai Airport Free Zone - Dubai, UAE
tel. +971 42146733
fax +971 42146734
www.faac.ae

NORDIC REGIONS

FAAC NORDIC AB
Perstorp, Sweden
tel. +46 435 779500
fax +46 435 779529
www.faac.se

POLAND

FAAC POLSKA SP.ZO.O
Warszawa, Poland
tel. +48 22 8141422
fax +48 22 8142024
www.faac.pl

SPAIN

F.A.A.C. SA
Alcobendas - Madrid, Spain
tel. +34 91 6613112
fax +34 91 6610050
www.faac.es

SWITZERLAND

FAAC AG
Altdorf, Switzerland
tel. +41 41 8713440
fax +41 41 8713484
www.faac.ch

UNITED KINGDOM

FAAC UK LTD.
Basingstoke - Hampshire, UK
tel. +44 1256 318100
fax +44 1256 318101
www.faac.co.uk

U.S.A.

FAAC INTERNATIONAL INC
Jacksonville, FL - U.S.A.
tel. +1 904 4488952
fax +1 904 4488958
www.faacusa.com

FAAC INTERNATIONAL INC

Fullerton, California - U.S.A.
tel. +1 714 446 9800
fax +1 714 446 9898
www.faacusa.com

